

* Customer :

PRELIMINARY

SPECIFICATIONS

MODEL	UV LED
PART NO.	P8D236

[Contents]

1. Device Material	-----2
2. Outline Dimension	-----2
3. Absolute Maximum Ratings	-----3
4. Electro-optical Characteristics	-----4
5. Reliability Tests	-----5
6. Characteristic Diagrams	-----6
7. Recommended Soldering	-----8
8. Soldering Profile	-----9
9. Packing	-----10
10. Precaution for use	-----12

CUSTOMER

Checked by	Approved by

SUPPLIER

Drawn by	Checked by	Approved by

1. DEVICES MATERIALS

Part Number	Package	Window	Electrodes
P8D236	Metal & Plastic	Silicone Resin	Ag Plating

2. OUTLINE DIMENSIONS

TOP VIEW

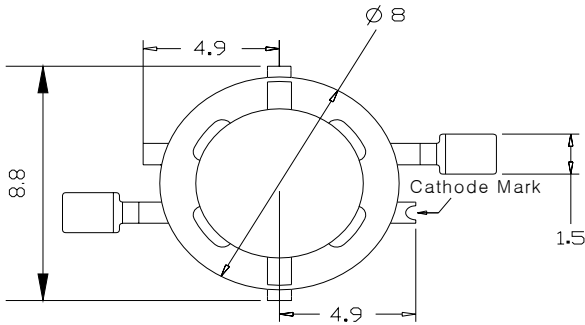

BOTTOM VIEW

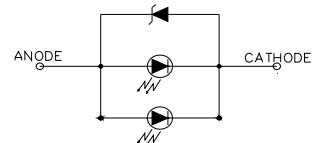
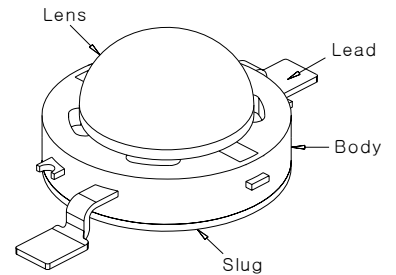
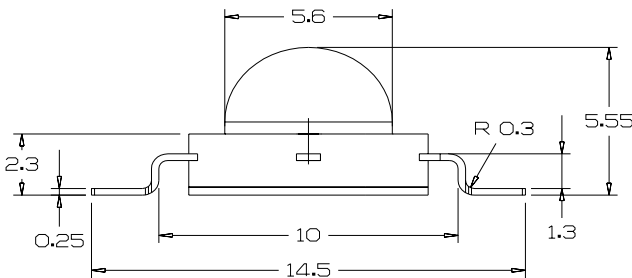
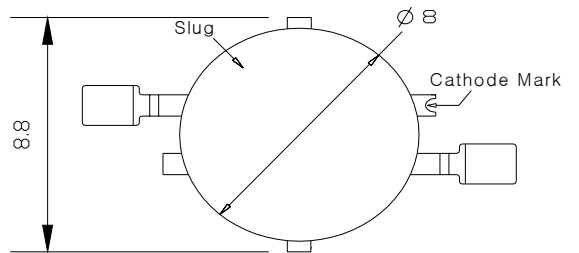

Notes : 1. All dimensions are in millimeters.(Tolerance : ± 0.2)

3. ABSOLUTE MAXIMUM RATINGS (at $T_a = 25^\circ\text{C}$)

Item	Symbol	Value	Unit
DC Forward Current	I_F	800	mA
Reverse Current	I_R	85	mA
Power Dissipation	P_D	3.6	W
Operating Temperature	T_{opr}	-30 ~ +85	$^\circ\text{C}$
Storage Temperature	T_{stg}	-40 ~ +100	$^\circ\text{C}$
LED Junction Temperature	T_j	125	$^\circ\text{C}$

4. ELECTRO-OPTICAL CHARACTERISTICS (at $I_F = 700\text{mA}$, $T_a = 25^\circ\text{C}$)

Item	Symbol	Value			Unit
		Min.	Typ.	Max.	
Forward Voltage ¹	V_F	-	4.1	4.6	V
Peak Wavelength ²	λ_P	360	365	370	nm
Spectrum Half Width	$\Delta\lambda$	-	18	-	nm
View Angle	$2\theta_{1/2}$	110			Deg.
Optical Power Output ³	P_O	-	75	-	mW

Note : 1. Forward Voltage Measurement allowance : $\pm 3\%$

2. Peak Wavelength Measurement allowance : $\pm 3\text{nm}$

3. Optical Power Output Measurement allowance : $\pm 10\%$

5. RELIABILITY TESTS

(1) TEST ITEM AND RESULT

Item	Condition	Note	Failures
Operating Life Test *	$T_a = RT, I_F = 800mA$	500 hrs	0/10
High Temperature Operating *	$T_a = 85^{\circ}C, I_F = 300mA$	500 hrs	0/10
Low Temperature Operating *	$T_a = -30^{\circ}C, I_F = 700mA$	500 hrs	0/10
Thermal Shock	$T_a = -40^{\circ}C (30min) \sim 100^{\circ} (30min)$ (Transfer Time : 5sec, 1cycle : 1hr)	100 cycles	0/10
Resistance to soldering Heat (Reflow Soldering)	$T_s = 240 \pm 5^{\circ}C, t = 5 \pm 1sec$	1 time	0/10
High Temperature Storage	$T_a = 100^{\circ}C$	500 hrs	0/10
Low Temperature Storage	$T_a = -30^{\circ}C$	500 hrs	0/10

*Tested with SOC's standard Metal PCB & Heat sink ($R_{ja} \approx 20^{\circ}C/W$)

(2) CRITERIA FOR JUDGING THE DAMAGE

Item	Symbol	Measuring Condition	Criteria for Judgement	
			Min.	Max.
Forward Voltage	V_F	$I_F = 700mA$	-	USL ¹ X 1.2
Optical Power Output	P_O	$I_F = 700mA$	LSL ² X 0.7	-

Notes : 1. USL : Upper Standard Level

2. LSL : Lower Standard Level.

6. CHARACTERISTIC DIAGRAMS

$$I_{rel} = f(\lambda_p), T_a = 25^\circ\text{C}, I_F = 700\text{mA}$$

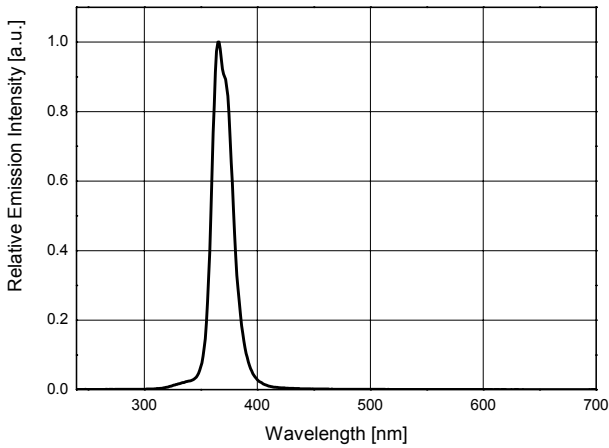

Wavelength Characteristics

$$I_F = f(V_F), T_a = 25^\circ\text{C}$$

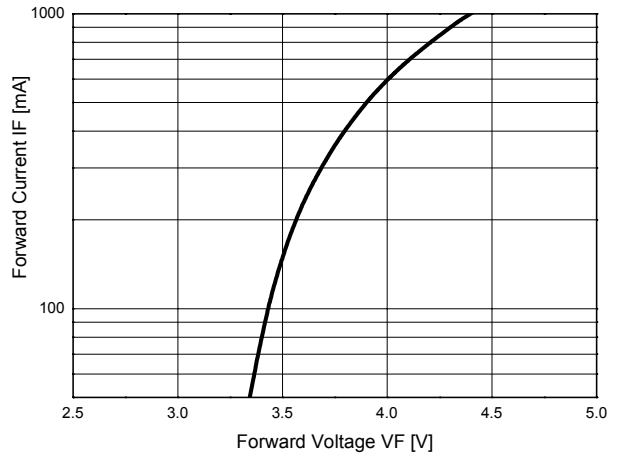

Forward Voltage vs. Forward Current

$$P_{Rel} = f(I_F), T_a = 25^\circ\text{C}$$

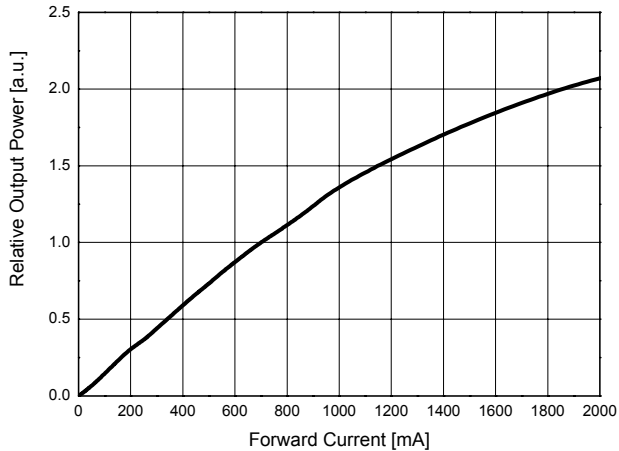

Forward Current vs. Relative Output Power

$$I_F = f(T_a), T_a = 25^\circ\text{C}$$

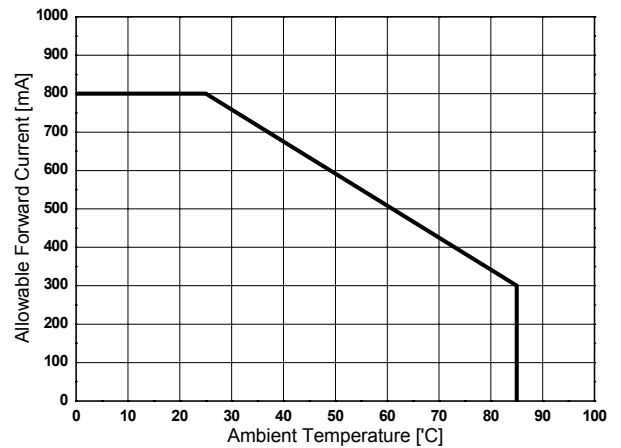

Ambient Temperature vs. Forward Current

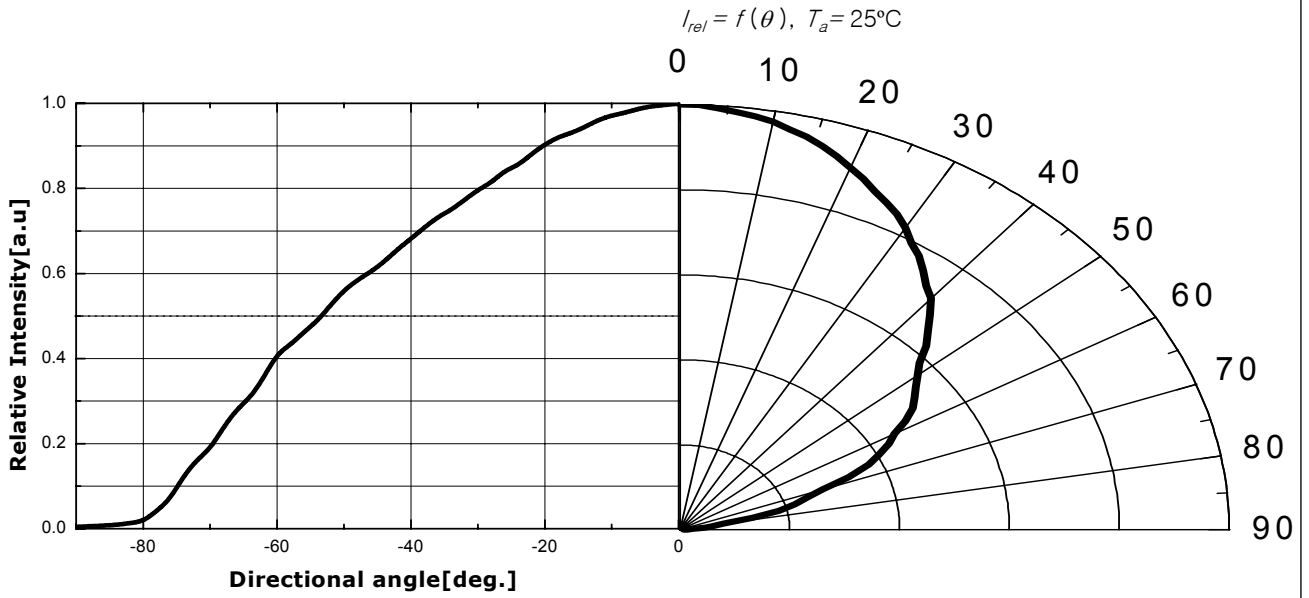

Off Axis Angle vs. Relative Output Power

7. RECOMMENDED SOLDERING

(1) Solder Pad

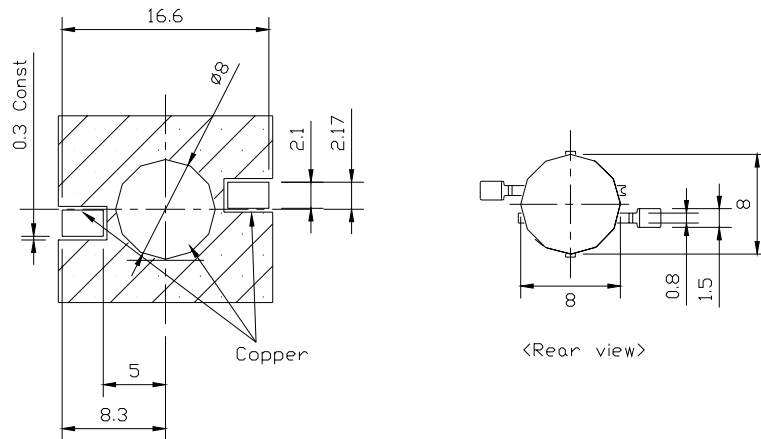
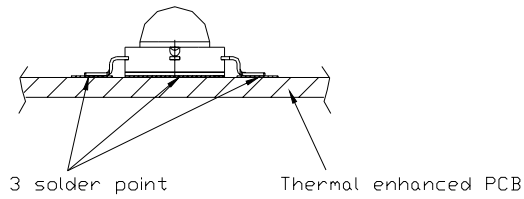

7.2. Solder Paste Pattern

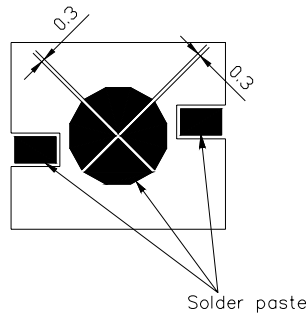

Notes : 1. Paste thickness : 0.2mm.

2. All dimensions are in millimeters (tolerance : ± 0.2)

3. Scale none

*The appearance and specifications of the product may be changed for improvement without notice.

8. SOLDERING PROFILE (Ta=25°C)

(1) Reflow Soldering Conditions / Profile

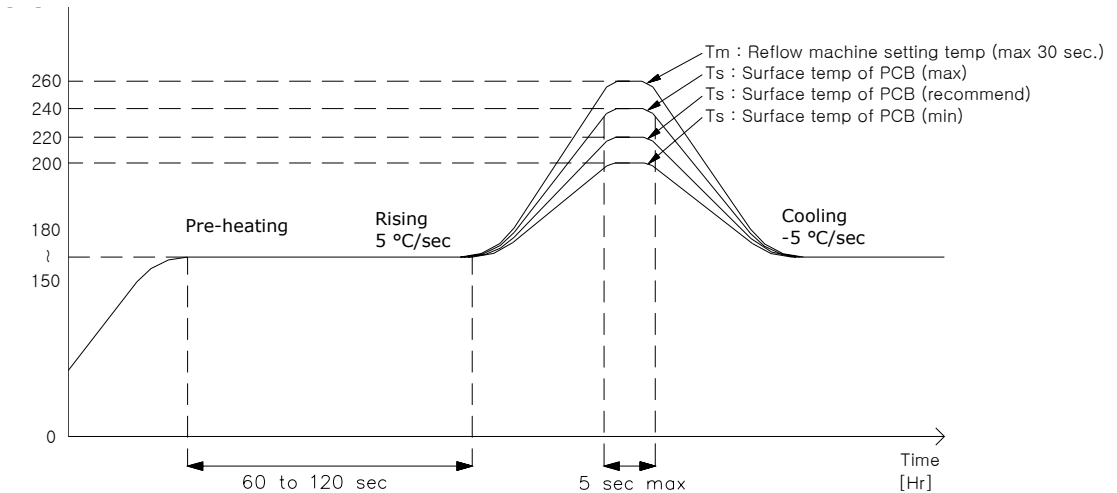

(2) Hand Soldering Conditions

Lead : No more than 3 seconds @MAX280 °C
Slug : Use a thermal-adhesives

* Caution

1. Reflow soldering should not be done more than one time.
2. Repairing should not be done after the LEDs have been soldered. When repairing is unavoidable, suitable tools have to be used.
3. Die slug is to be soldered.
4. When soldering, do not put stress on the LEDs during heating.
5. After soldering, do not warp the circuit board.
6. Recommend to use a convection type reflow machine with 7 ~ 8 zones.

9. Packing

(1) Emitter Reel Packaging

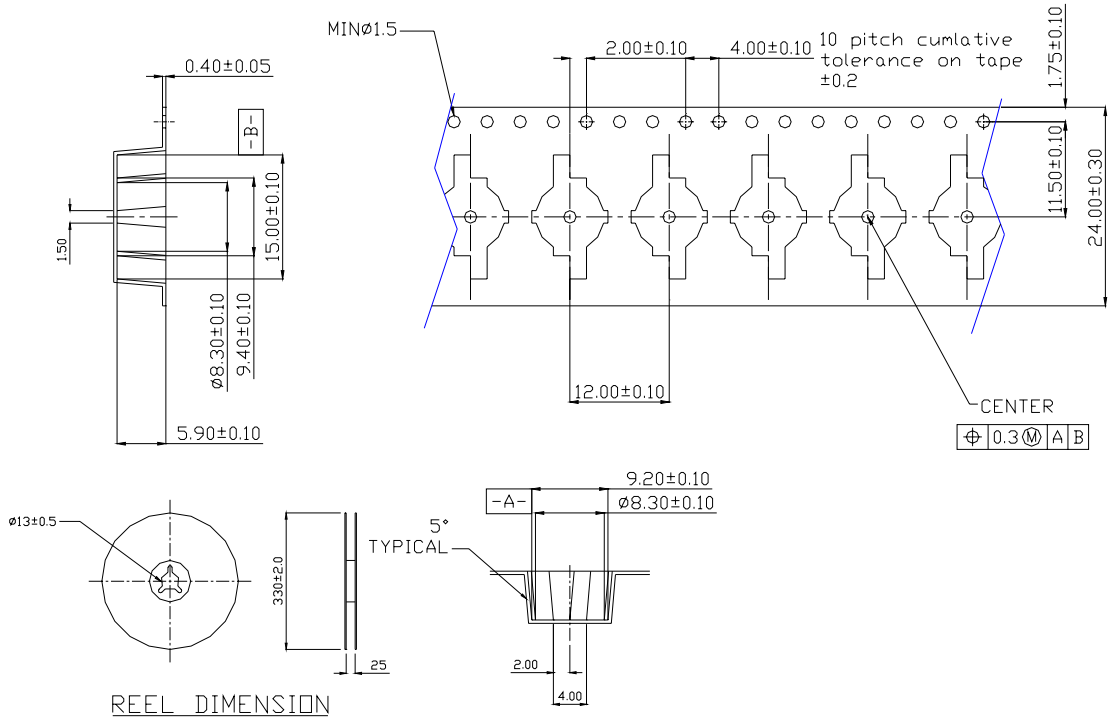

(2).Packing structure

Aluminum Vinyl Bag

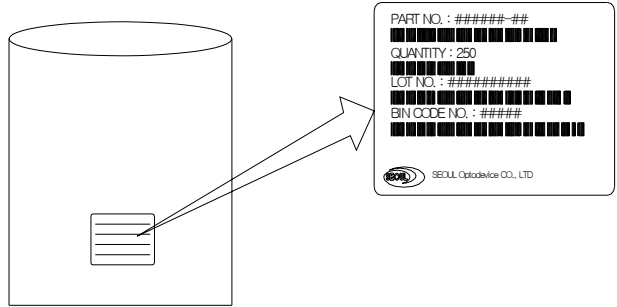

Outer Box

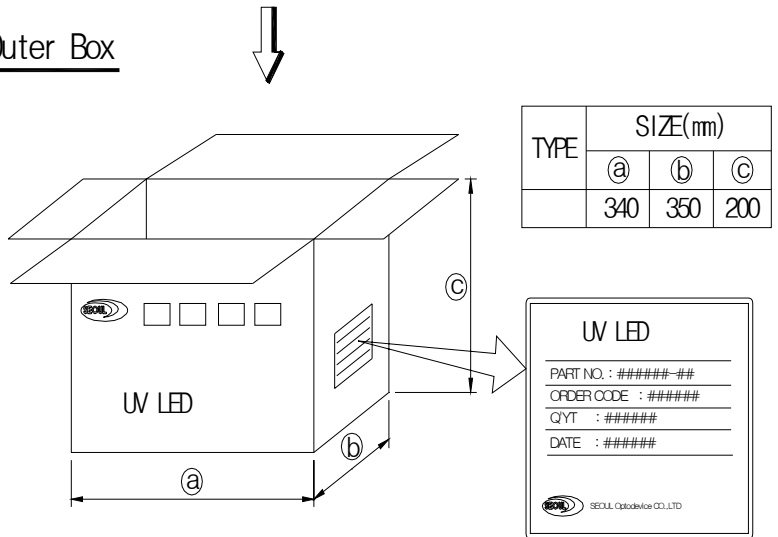

Note :

1. 5 reels are loaded in box
2. Scale none

10. Precaution for use

1) Cautions

- The devices are UV LEDs. The UV LED during operation radiates UV light, which precautions must be taken to prevent looking directly at the UV light with unaided eyes. Do not look directly into the UV light or look through the optical system. When there is a possibility to receive the reflection of light, protect by using the UV light protective glasses so that light should not catch one's eye directly.



2) Storage

- Before opening the package
 - Avoid the absorption of moisture, we recommended to store the LEDs in a dry box(or desiccator) with a desiccant . Otherwise, store them in the following environment:
Temperature : 5℃~30℃ Humidity : 50% max.
 - The products should be used in 3 months. It is recommended that the LEDs be used as soon as possible.
- After opening the package
 - Soldering should be done right after opening the package(within 24Hrs).
 - Keeping of a fraction:
 - Sealing
Temperature : 5 ~ 40℃, Humidity : less than 30%
 - If the package has been opened more than 1week or the color of desiccant changes, Components should be dried for 10~12hr at 60±5℃
 - Any mechanical force or any excess vibration shall not be accepted to apply during cooling process to normal temp. after soldering.
 - Avoid quick cooling
 - Please avoid conditions which may cause the LEDs to corrode, tarnish or discolor.

3) Static Electricity

- Static Electricity and surge voltage damage the LEDs. So it is recommended that a wrist band or an anti-electrostatic glove be used when handling the LEDs.
- All devices, equipment and machinery must be grounded properly. It is recommended that precautions should be taken against surge voltage to the equipment that mounts the LEDs.

4) Heat Generation

- Heat is one of the important parameters to design the end product. Please consider the heat generation of the LEDs.
- The operating current should be decided after considering the ambient maximum temperature of LEDs.

6) Others

- Anti radioactive ray design is not considered for the products listed here.
- This device should not be used in any type of fluid such as water, oil, organic solvent and etc. When washing is required, IPA(Isopropyl Alcohol) should be used.
- When the LEDs are illuminating, operating current should be decided after considering the junction temperature.

Cf.) Please refer *Ambient temperature vs. Forward Current* graph on page 6

- The appearance and specifications of the product may be modified for improvement without notice.